

FPT2600E & FPT2600-EX1

Handheld Fuel Cap Test Systems

User Guide

HICKOK WAEKON

© 2022 Hickok Waekon. All rights reserved.

No part of this manual may be reproduced or transmitted in any form or by any means, electronic or mechanical, without written permission from Hickok Waekon.

Hickok Waekon assumes no responsibility for use of this equipment by untrained or unauthorized persons.

Printed in the United States of America.

Contents

Safety Information	4
Overview	5, 6, 7
Fuel Cap Tester.....	6, 7
Pass/Fail Standard—Applies only to FPT2600-EX1	8
Checking the Tester’s Flow Rate Calibration.....	9, 10
Applies only to FPT2600-EX1	9
Setup.....	11
Setup and Testing	11
Testing	12
Maintenance	13
General Maintenance.....	13
Replacing the Batteries	14
Contact Information	15
Warranty.....	16

Safety Information

Before using this equipment, carefully read, understand and follow instructions and safety messages on equipment and in this guide.

This guide cannot anticipate or provide advice and cautions for all situations encountered by technicians. With this in mind, always follow and refer to the manuals provided by the manufacturer of the vehicle or equipment being tested or used for all information and testing procedures whenever diagnosing, repairing or operating such vehicle or equipment.

Failure to follow the instructions, cautions and warnings provided here as well as those provided by the vehicle and equipment manufacturers can result in fire, explosion, bodily injury and property damage.

In addition to the information listed below, additional warnings and cautions are listed throughout the guide. Please read them carefully.

Fuel vapors are toxic and explosive, which can cause severe injury or death.

- Use proper ventilation to avoid breathing fuel vapors.
- Minimize contact with the skin with the use of gloves (such as nitrile gloves) when there is possibility of getting methanol fuel on your hands.
- If the skin is directly exposed, wash the area immediately and change any clothes that have become wet with fuel.
- Always wear approved safety glasses when testing. Should fuel get into eyes, flush eyes immediately with water and consult your physician.

Vehicles emit flammable vapors which can ignite.

- Keep flames, sparks, cigarettes and other ignition sources away from the vehicle at all times.
- In case of fire, never use water to fight flames caused by methanol or methanol blended gasoline. This will cause the flames to spread instead of extinguishing them.
- Use a dry chemical extinguisher to fight flames (preferably one marked ABC, though BC is acceptable). A foam extinguisher is acceptable only if it is ARF grade, which is resistant to alcohol.

Before beginning any tests, make sure the test environment is safe and the vehicle meets these testing conditions:

- Test area should be well ventilated.
- Vehicle should be in park.
- Wheels should be blocked.
- Engine should be at normal operating temperature.
- Vehicle should have normal exhaust flow.
- Keep all tester cables clear of exhaust manifolds and radiator fan blades.
- Use caution when testing on a vehicle while the engine is running (surfaces may become hot, electric cooling fans may turn on unexpectedly, etc.)

Overview

This User Guide explains how to use both the FPT2600E Handheld Fuel Cap Tester and the FPT2600-EX1 Handheld Fuel Cap Tester Kit. Both testers operate in the same manner.

FPT2600E

The FPT2600E includes:

- Fuel Cap Tester
- Black Fuel Cap Adapter

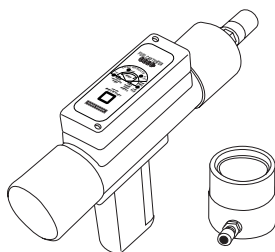

FPT2600-EX1

The FPT2600-EX1 includes:

- Fuel Cap Tester
- Pass/Fail Standard
- Black Fuel Cap Adapter plus an additional nine adapters
- Storage Case

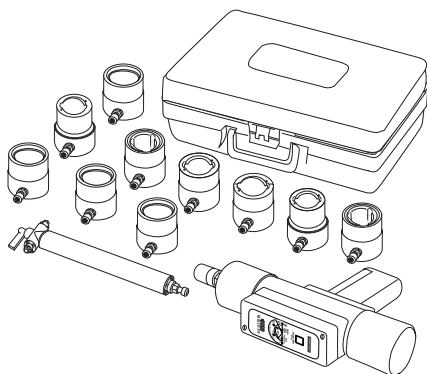

Before You Begin

- Please read the instructions carefully before using the tester. Failure to follow the instructions may cause incorrect test results.
- **Before** using the tester for the **first time**, remove the battery protector pull tab.
- Make sure the vehicle is turned off **before** removing the fuel cap.
- When removing the fuel cap, do so **slowly** and allow any pressure to decay **before** fully removing the cap.
- Because residual pressure from a previous test will cause an incorrect auto zero, **never** power up the tester with the fuel cap connected to the adapter.

Overview

Fuel Cap Tester

Applies to FPT2600E and FPT2600-EX1

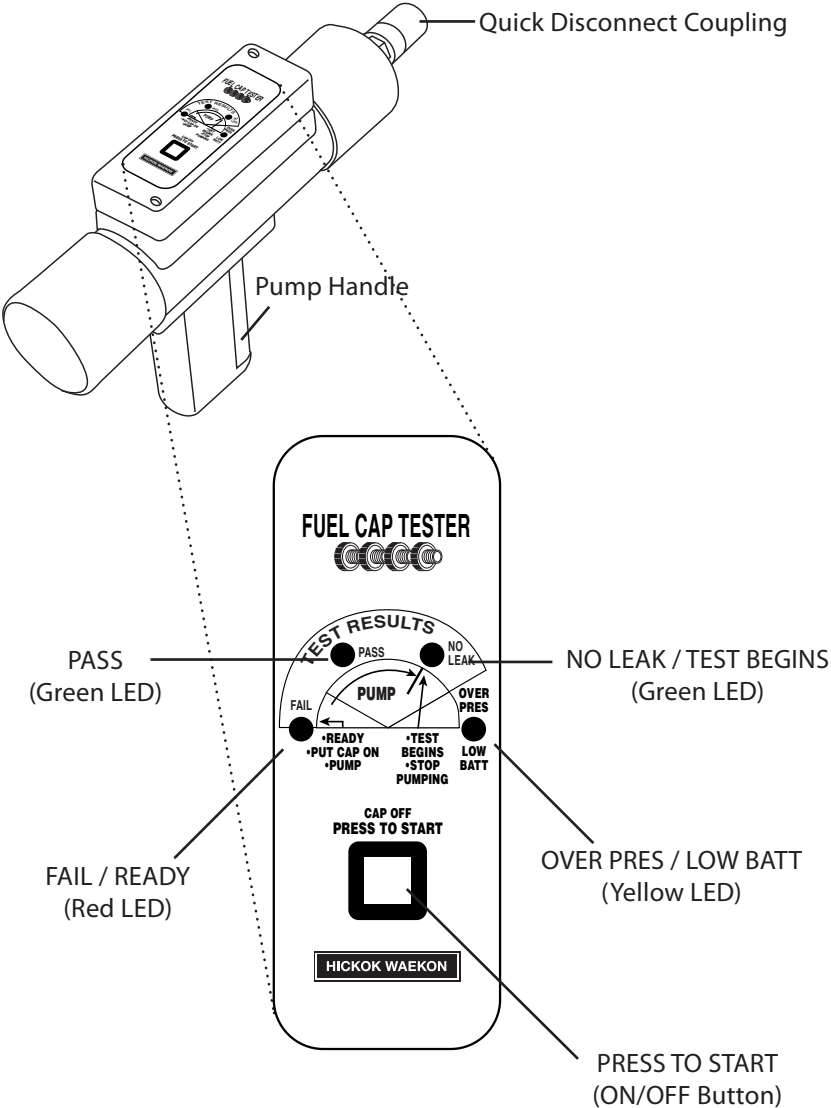

PRESS TO START (ON/OFF Button)—Pressing this button turns the power on and off.

- Turning on the unit also initiates tester auto zero and the start of the test.
- The tester automatically turns off if the test is not started within 20 seconds after the unit is turned on.
- The tester also turns off automatically after the test result LED flashes.

PASS (Green LED)—Flashes at the end of the test if the cap leak down test passes (pressure loss is within acceptable specification).

- Steady light on after power up indicates auto zero is in progress.
- Steady light on during pumping indicates the pressure to the cap is being built up.

FAIL / READY (Red LED)—Flashes at end of test if cap leak down test fails.

- Steady light on indicates auto zero is complete and the unit is ready to start the test.

NO LEAK / TEST BEGINS (Green LED)—Flashes at end of test if cap leak down test passes and no pressure loss is measured.

- Steady light on during pumping indicates pressure to cap is sufficient to perform test—stop pumping.

OVER PRES / LOW BATT (Yellow LED)—Flashes after power on to indicate battery voltage is low. Batteries must be replaced before testing is performed.

- Steady light on during pumping indicates pressure to the cap is excessive and pumping should be stopped.

Quick Disconnect Coupling—Allows quick changing of cap adapters and provides a way to update the tester with new adapters as needed.

Pump Handle—Provides a quick and easy way to build up the necessary pressure for testing.

Overview

Pass/Fail Standard—Applies only to FPT2600-EX1

Allows you to verify that the tester is calibrated properly.

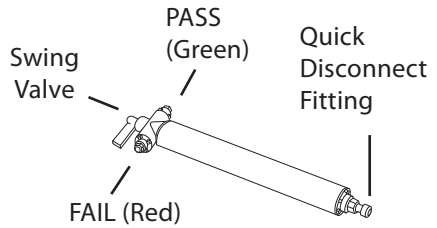

Storage Case and Fuel Cap Adapters—Applies only to FPT2600-EX1 except for the Black Fuel Cap Adapter

Color coded for easy identification, the fuel cap adapters allow you to test most vehicle's fuel caps.

- **Black Cap Adapter**—Standard threaded cap, used for most vehicles.
- **Brown Cap Adapter**—Dual threaded cap. Typically used for 1996 Ford Explorer, 1999 or newer Chrysler vehicles, 2001 Mitsubishi and Nissan vehicles.
- **Orange Cap Adapter**—Three tab quick turn cap. Typically used for 1996 and newer Ford vehicles, 1997 and newer Mazda B-Series P.V.v., and 2001 Mazda Tribute.
- **Blue Cap Adapter**—Two tab quick turn cap. Typically used for 1996 and newer GM vehicles.
- **Red Cap Adapter**— $1\frac{1}{2}$ " shallow cam. Typically used for Acura, Audi, BMW, 1970's Fords, IHC, Jaguar, Mazda, Mercedes, and VW.
- **Gray Cap Adapter**— $1\frac{3}{8}$ " shallow cam. Typically used for AMC, Audi, Chrysler, Isuzu, Jeep, Nissan, Renault, Subaru, Toyota, and VW.
- **Yellow Cap Adapter**— $1\frac{1}{2}$ " deep cam. Typically used for mid 1970's Ford trucks, IHC, Winnebago, and Mercury Capri.

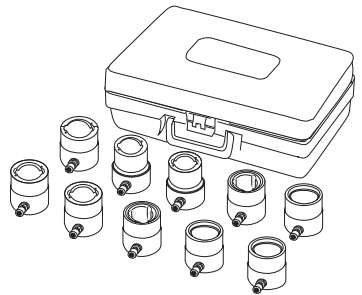

- **Purple Cap Adapter**—Typically used for late model VWs.
- **Pink Cap Adapter**—Typically used for 1997 and newer BMW, Mini Cooper, and Mercedes.
- **Green Cap Adapter**—1½" deep cam. Typically used for mid 1970's Ford trucks, IHC, Winnebago, and Mercury Capri.

Checking the Tester's Flow Rate Calibration

Applies only to FPT2600-EX1

Always check the tester's flow rate calibration before initial use for certified vehicle testing and before testing begins each day. Failure to check the tester's calibration may cause inaccurate test results. There are two parts to this test—one with the swing valve set to Pass, and the other with the valve set to Fail.

- Do not attach the Pass/Fail Standard to the tester until after the power is on.
- Install the Pass/Fail Standard and start the test as soon as possible after auto zero.
If testing is not started within one minute after auto zero, the tester will shut itself off. If this happens, repeat the instructions for the calibration test from the beginning.
- Do not disturb (turn or press) the Pass/Fail Standard during pumping and testing.

IMPORTANT! If the Flow Rate Calibration Check fails, do not use the tester for certified testing. Contact Hickok/Waekon Customer Service for technical assistance.

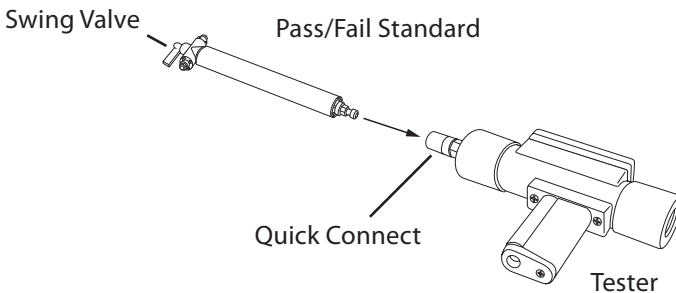

Calibration

Procedure—Part 1

1. Set the Pass/Fail Standard swing valve to **PASS** (green).
2. Push the **Press To Start** button to turn the tester on. The LEDs will light in the following order:
 - All LEDs will light briefly.
 - The green **PASS** LED will turn on during the auto zero function and then turn off.
 - The red **READY** LED turns on indicating the tester has auto zeroed and is ready for testing.
3. Immediately install the Pass/Fail Standard to the tester's quick disconnect fitting to begin the test.
4. With the Pass/Fail Standard connected to the tester and the tester powered on (red **READY** LED on), begin pumping the handle to build up pressure and start the test.

Continue pumping as the **PASS** LED turns on, stopping after the **NO LEAK** LED turns on. The 10 second test is automatically initiated.

*Note: If the **OVER PRES** LED turns on, stop pumping immediately and allow test to start.*

At the end of the test, the results are displayed by the tester flashing the appropriate LED:

Test Passed—Green **PASS** LED flashes

Test Failed—Red **FAIL** LED flashes, or the standard cannot be pressurized (the No Leak LED will not turn on with continued pumping)

Procedure—Part 2

1. Follow the same instructions for part 1 except set the swing valve to Fail (Red).

Setup and Testing

Setup

Applies to FPT2600E and FPT2600-EX1

1. Remove the fuel cap from the vehicle and inspect for the following:
 - Damage to the fuel cap—if damaged, replace with new cap
 - Cracked or missing gasket—if damaged or missing, replace with a new gasket.
 - Dirty gasket—clean gasket or replace if necessary

IMPORTANT! Allow any fuel on the cap to evaporate before continuing.

2. Connect the appropriate adapter to the tester's quick disconnect fitting. Remember, do not attach the fuel cap until after the tester is turned on.

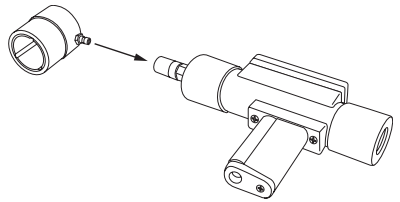

3. Push the **PRESS TO START** button to turn the tester on. The LEDs will light in the following order:
 - All LEDs will light briefly.
 - The green **PASS** LED will turn on to indicate the auto zero function is running, and then turns off.
 - The red **READY** LED turns on indicating the tester has auto zeroed and the unit is ready for testing.

4. Immediately install the fuel cap on to the adapter to begin testing. Make sure the cap is firmly seated

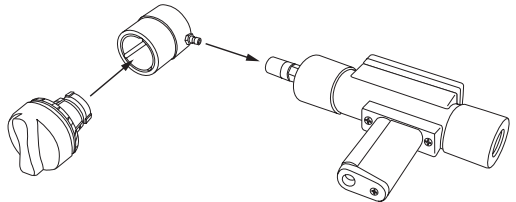

Note: If testing is not started within 20 seconds after auto zero, the tester will turn off. If this happens, remove the cap and return to the beginning of the setup procedure and start again.

Setup and Testing

Testing

Applies to FPT2600E and FPT2600-EX1

1. With the adapter and fuel cap connected to the tester, and with the tester power on (red **READY** LED on) , begin pumping the handle to build up pressure and to start the test.

While pumping the handle, the green **PASS** LED will turn on.

2. Continue pumping until the green **NO LEAK** LED turns on, then stop pumping. The test is automatically initiated at this point.

*Note: If the **OVER PRES** LED turns on, stop pumping immediately and allow test to start.*

At the end of the test, the results are displayed by the tester flashing the appropriate LED:

Test Passed—Green **PASS** LED flashes (indicates a slight pressure drop, but within pass specifications) or,

The green **PASS** LED and the green **NO LEAK** flashes (indicates no pressure drop is measured)

Test Failed—Red **FAIL** LED flashes, or

The cap cannot be pressurized (the **NO LEAK** LED will not turn on with continued pumping) or,

The cap is obviously damaged or it is not the correct cap for the test vehicle.

3. Once the fuel cap has passed testing, inspect the vehicle's fuel filler (fuel cap retainer) for thread and seat damage. If necessary, repair or replace.
4. Testing is complete.

If the cap passed—Put the cap back on the vehicle.

If the cap failed—Remove the cap from the adapter and inspect the gasket for cracks or debris build-up. Clean the gasket if necessary and retest. If the cap still fails, it should be replaced.

General Maintenance

Applies to FPT2600E and FPT2600-EX1

The following are recommended steps to help keep your tester in good working condition:

- Keep the tester and adapters clean. Pay special attention to the quick disconnect couplings.
- Store the tester and adapters in their storage cases when not in use.
- When using the tester, occasionally rotate the pump body in the handle. This helps increase the life of the pump body.

If the tester has not been used for awhile, do the following before using:

- Pump the handle vigorously several times to free the check valves.
- If needed, the check valves may be lubricated with a *small* amount of silicon spray lube.

To remove the pump, firmly grasp it and pull down and out.

When inserting the pump, make sure the end with the O-ring is positioned up towards the tester's body.

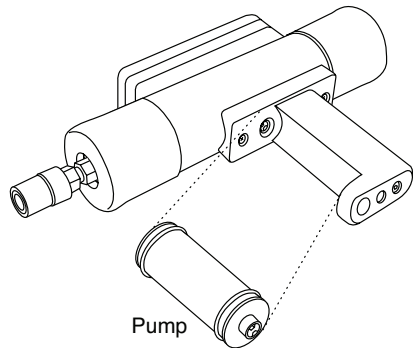

Maintenance

Replacing the Batteries

Applies to FPT2600E and FPT2600-EX1

Low battery voltage is indicated when all LEDs blink several times as the tester is turned on. For accurate test results, the batteries should be changed at this time.

The tester uses three standard CR2032 3 volt lithium batteries.

To replace the batteries:

1. To gain access to the batteries, remove the two screws on the top of the tester.
2. Remove the three old batteries from the circuit board (see figure 3). Use caution so as not to damage the battery holders, components on the circuit board, or the pressure tube.
3. Install three new batteries in the tester. Make sure they are positioned properly for polarity.
4. Replace the cover and the two screws. Do not over tighten.

The fuel cap tester is now ready to use.

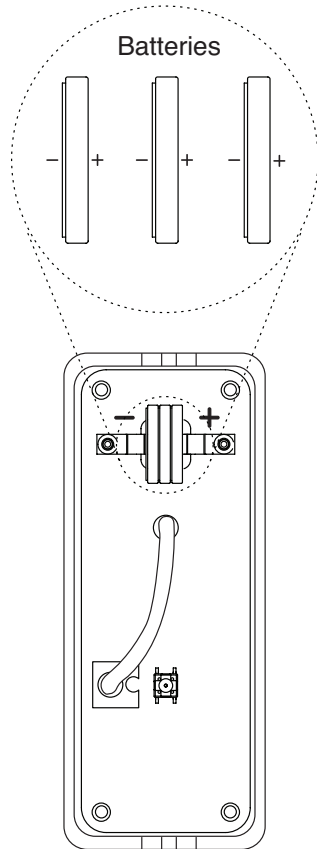

Fig. 3

Contact Information

If you have any questions about our products including technical assistance, call our customer care department during standard business hours EST. If a customer care representative directs you to return any equipment, be sure to include these items:

- a written description of the problem;
- the name and telephone number of your contact person;
- your shipping address, and
- our return authorization number (from customer care).

Customer care and tech support:	800/342-5080
Service and repair center:	662/453-6212
Fax:	216/761-9879
E-mail:	support@hickokwaekon.com repaircenter@hickokwaekon.com
Service address:	Hickok Waekon Automotive Group 1716 Carrollton Avenue Dock E Greenwood, MS 38930



Visit our website at www.hickokwaekon.com

Get the latest product info & support, update your Hickok Waekon software, locate a distributor, and more. . .



Like Us on facebook at www.facebook.com/hickokwaekon

Learn about new products & promotions, tell us what new products you'd like to see, got a product question? Ask our Master Technicians!



Subscribe to our video channel at www.youtube.com/hickokwaekon

Watch the latest product and how-to videos.



Sign-up for email alerts at www.hickokwaekon.com

Be the first to hear about new products & services, promotions, and more...

Warranty

Subject to the conditions that follow and are noted below, this product is warranted to be free from defects in material and workmanship, under proper use and in accordance with the manufacturer's written recommendation and specifications, for a period designated below on all products:

- For all electronic parts and for the FPT series of evaporative equipment (both mechanical and electronic parts), a one-year limited warranty is in effect from the time of the purchase of the new product by the initial end user.
- For all hard parts (including mechanical and machined parts), other than listed in the preceding paragraph, a lifetime limited warranty is in effect from the time of the purchase of the new product by the initial end user.

The manufacturer's obligation under this warranty is limited to unaltered products returned to the manufacturer by the initial end user of the new products. Therefore, this warranty does not cover any products resold by the end user to third parties, nor any reconditioned products sold as such, by the manufacturer. The sole remedy for any such defect shall be the repair, or replacement, of the product at the sole discretion of the manufacturer. This warranty does not cover expendable parts, such as batteries, nor does it cover shipping or handling. In addition, manufacturer is not liable for any loss or damage to product during shipping.

In the event it is determined that the product has been tampered with, or altered in any way, this warranty is void and all claims against the product will not be honored. All warranty claims must be submitted as outlined by the manufacturer and shall be processed in accordance with the manufacturer's established warranty claim procedures. These procedures include provisions that proof of purchase must be established (by either warranty card from the seller or by point of purchase receipt) and that the manufacturer will make every attempt to return ship the product within one business day from receipt of the returned product, freight prepaid.

In addition, all maintenance procedures, as outlined by the product manuals, should be followed for the warranty to be kept in force. Should the product not be used in accordance with procedures as specified, or if the product otherwise fails outside of the warranty, the manufacturer reserves the right to make such judgment and the party returning the product will be notified that written notification will be necessary to repair the product at a cost which the manufacturer deems as reasonable. The product will then be shipped back to the customer, COD; or as the manufacturer deems appropriate.

This is the only authorized manufacturer's warranty and is in lieu of all other expressed, or implied, warranties or representations, including but not limited to any implied warranties of merchantability or fitness or any other obligations on the part of the manufacturer. In no event will the manufacturer be liable for business interruptions, loss of profit, personal injury, costs of delays, or any special, indirect, incidental or consequential damages, costs or losses.

(See Contact information for telephone and fax numbers and shipping information.)